

PROJECT:

TITLE:

DESIGNED BY:

DRAWN BY:

CHECKED BY:

APPROVED BY:

QTY: 8

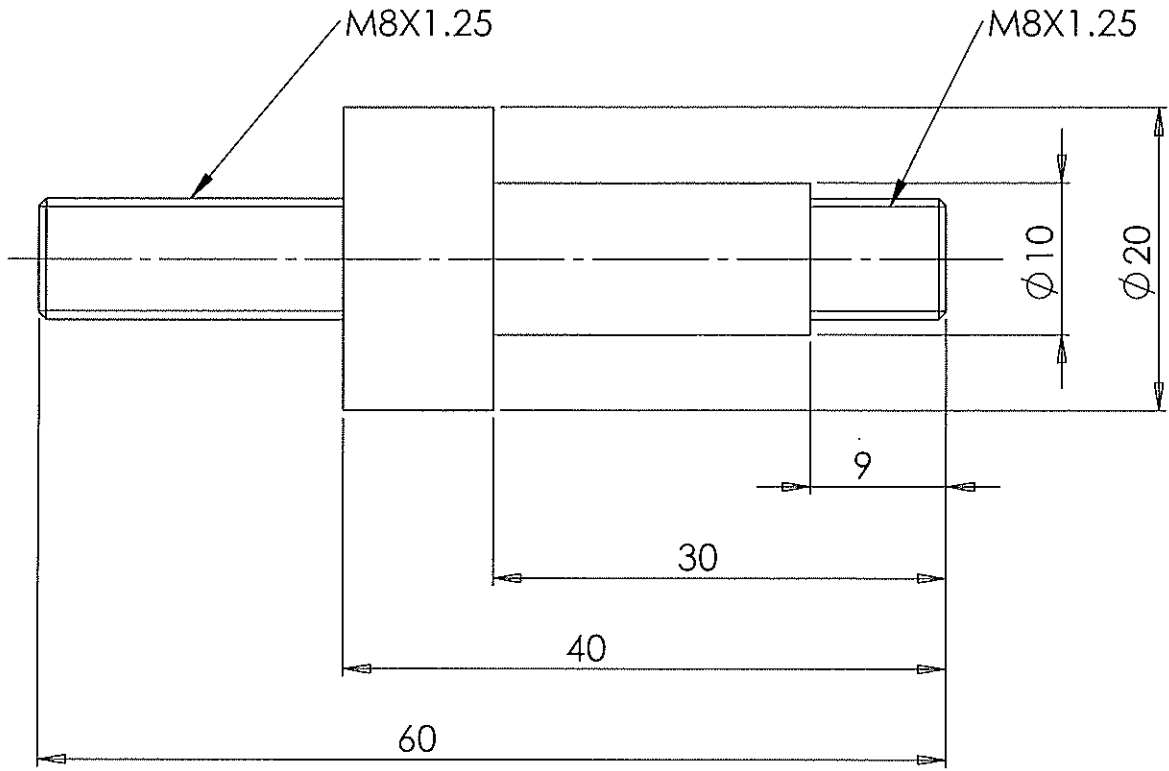

FINISH:

MATERIAL: mild steel

SCALE: 2:1

PROJECTION:

GENERAL MACHINING TOLERANCE

- .X  $\pm 0.20$
- .XX  $\pm 0.05$
- 0 TO 250  $\pm 0.5$
- 500 & ABOVE  $\pm 2.0$
- TIR  $\pm 0.20$
- ANGULAR  $\pm 1/4^\circ$

COMPANY:

Unspecified tolerance :  $\pm 0.5$



The HONG KONG  
POLYTECHNIC UNIVERSITY  
INDUSTRIAL CENTRE

1

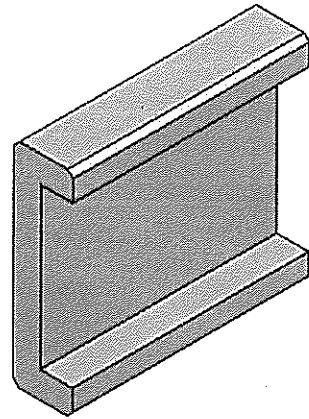
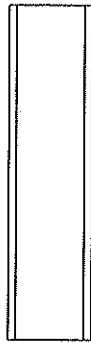

2

3

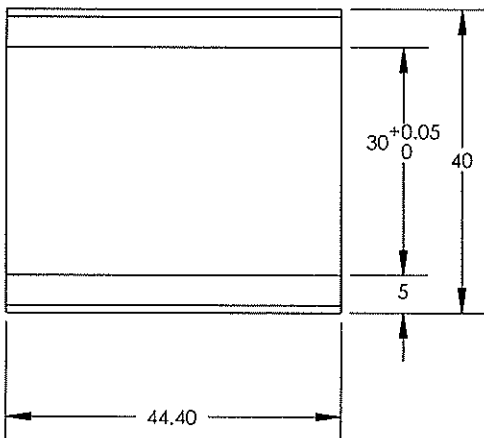
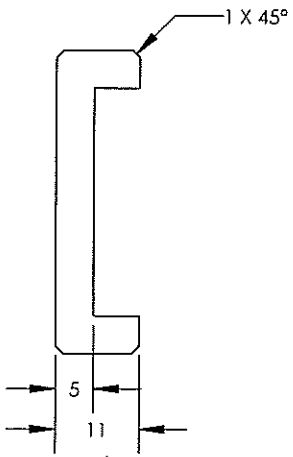

4

5

PROJECT:
TITLE: 1-2-15-000 R&P spacer
DESIGNED BY:
DRAWN BY:
CHECKED BY:
APPROVED BY:
QTY: 4
FINISH:
MATERIAL: Mild Steel
SCALE: 1:1
PROJECTION:
GENERAL MACHINING TOLERANCE .X ±0.20 .XX ±0.05 0 TO 250 ±0.5 500 & ABOVE ±2.0 TIR ±0.20 ANGULAR ±1/4°
COMPANY:
 The HONG KONG POLYTECHNIC UNIVERSITY INDUSTRIAL CENTRE

Unspecified tolerance : ± 0.2